

Lunar & Mars Surface Habitat Module

Abstract

The Aether Habitat Module is designed for crewed missions on the Moon and Mars. Fully operational within 30 days of launch, it eliminates complex assembly. Built with aerospace-grade materials, it offers 50.4m² of floor space for four crew members and meets NASA's standards for pressure containment, radiation shielding, and thermal regulation, providing a scalable solution for future lunar and Martian missions.

Objectives

- Design a prefabricated extraterrestrial habitat module for Lunar and Martian missions that can be fully manufactured on Earth and launched pressurized, ready for immediate deployment.
- Ensure the habitat is optimized for structural strength, thermal performance, and environmental protection under Lunar and Martian conditions.
- Complete physical and simulation testing to validate the module's performance for structural integrity, thermal efficiency, and environmental protection.

Physical Testing

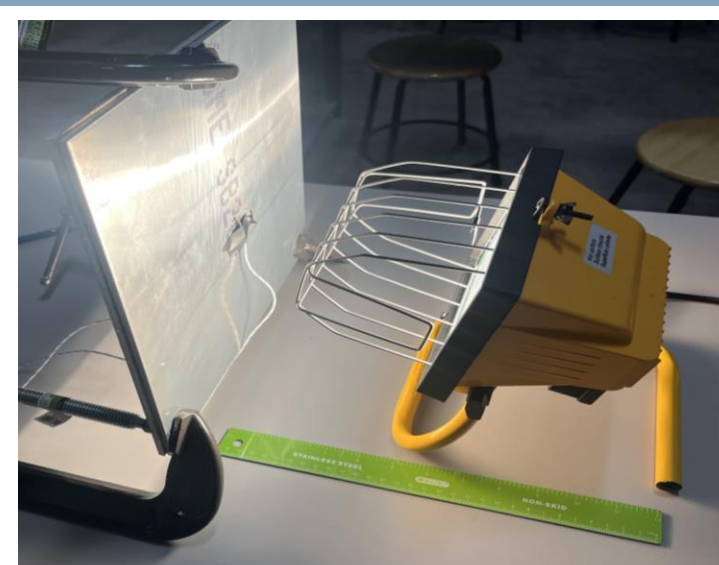

MLI Thermal Insulation
A controlled heat source was aimed at aluminum plates separated by MLI insulation, confirming the assumed conductivity constant used in simulations

Scale Layout Validation
A 1:15 scale model was constructed out of Aluminum 6061. Simplified assembly methods were utilized to construct a true scale model.



Component Section	Mass
Pressure Hull (Al-2219)	1800kg
Flooring and Supports (Floors, Spine, I beams, Leg Saddles)	617kg
Wall Layers (HDPE, MLI, Basotect)	2348kg
TOTAL Mass: 4765 kg	

Abdelmalik Abuhlimeh, Steven Alvarado, Alec Bell, Eddie Hidalgo, Brandon Portillo

Sponsor: Texas Space Grant Consortium Advisor: Dr. Mohammad Biswas- UT Tyler

Aether Module

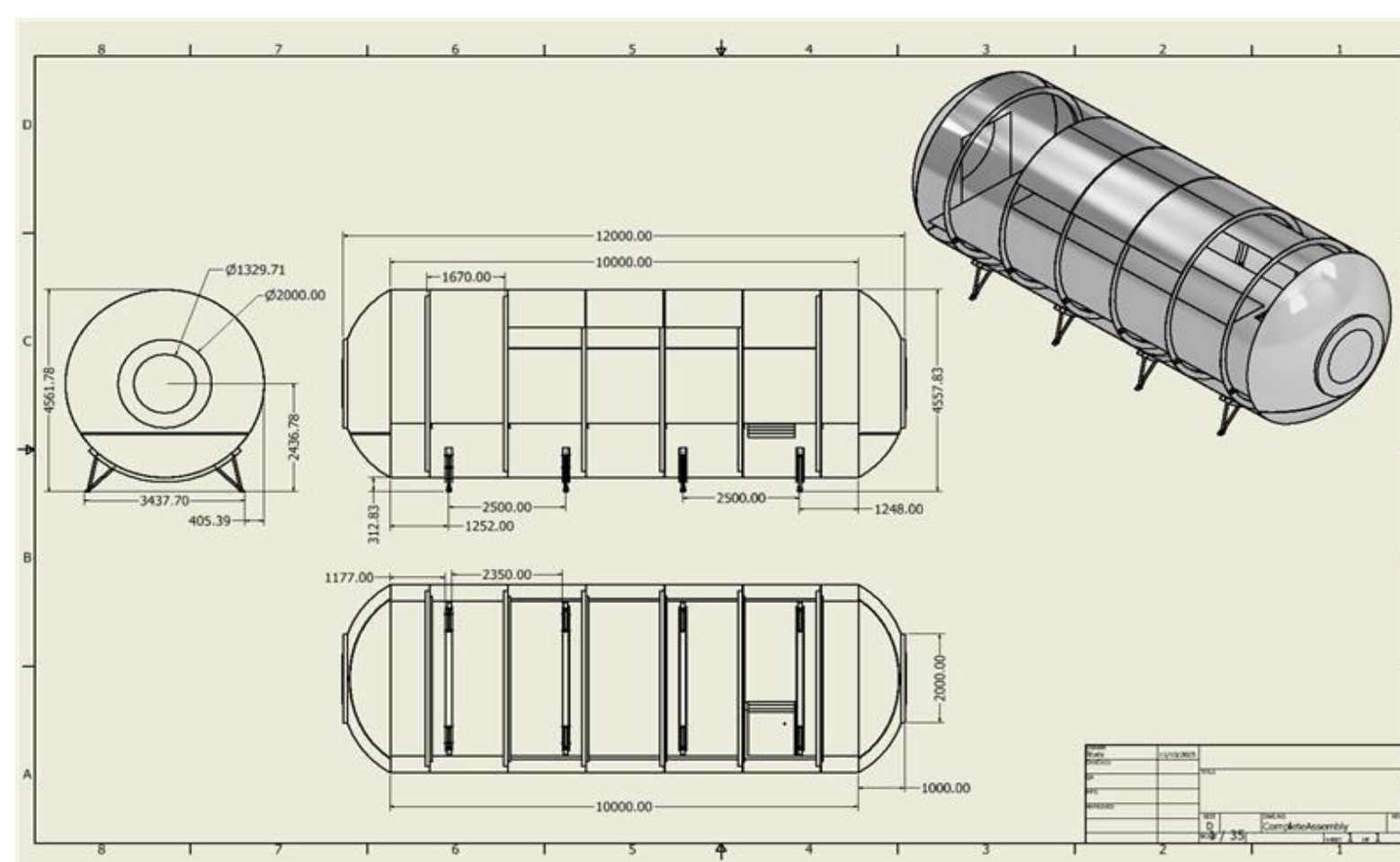

Aether Module Design View

Aether Module Deployed on Mars

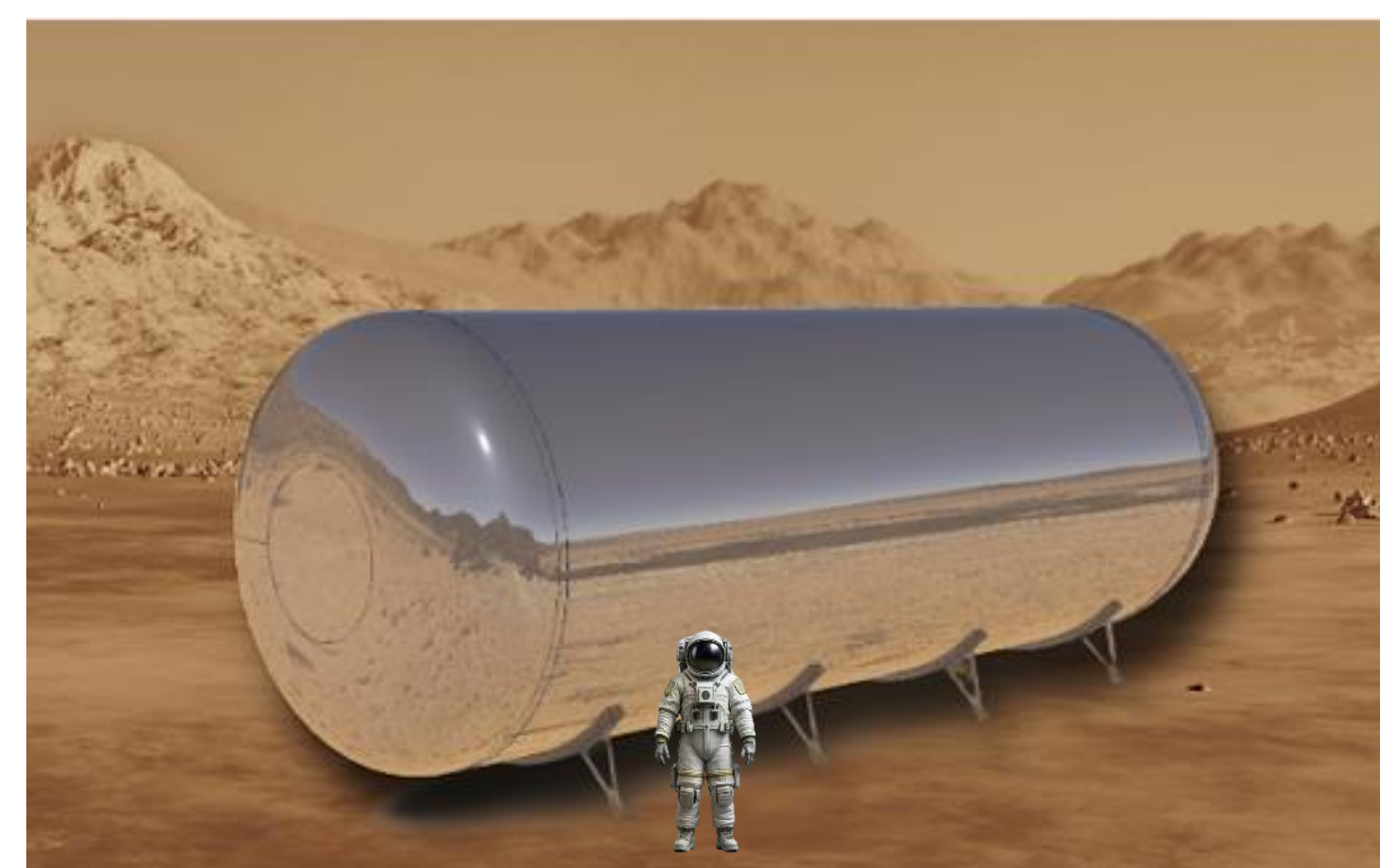

Habitat Main Components

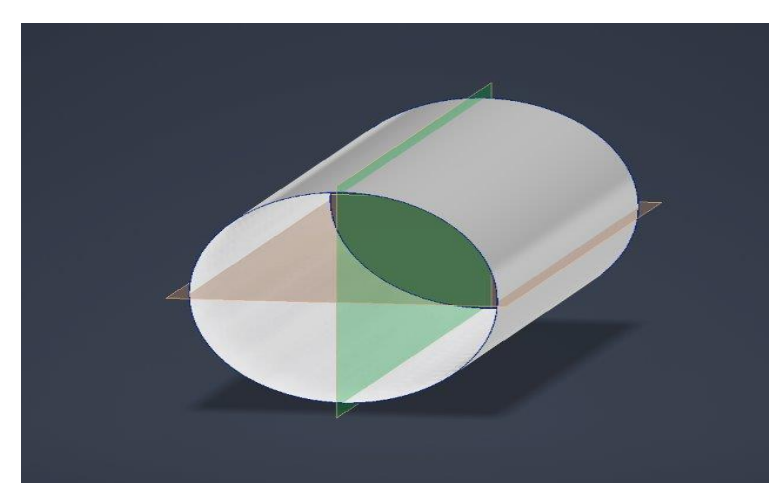

Pressure Shell

An aluminum 2219 pressure hull encases the module. This layer serves as the primary structural barrier, maintaining internal pressure while protecting the interior from external impact and environmental exposure.

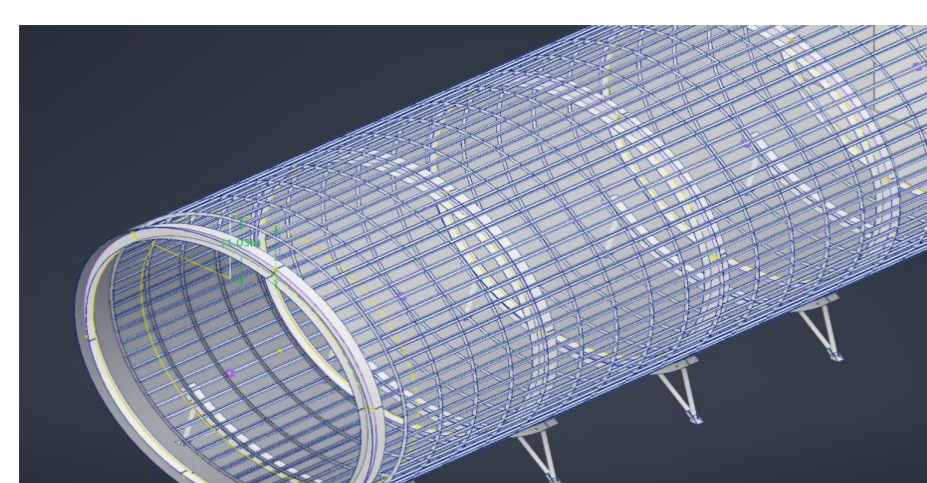

Support Spine

Al 7050 ribbed air frame style spine spans the module. The spine is responsible for resisting hoop stresses, transmitting loading forces to support beams and legs, and providing rigidity during launch

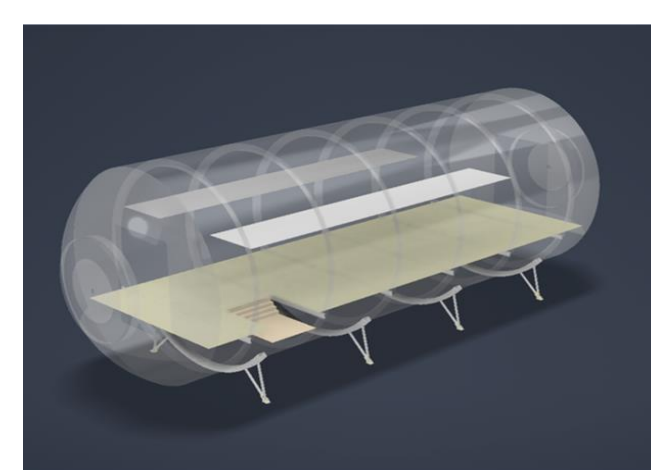

Main Floor & Lofts

Lower level workspace with overhead lofts for bunking total 50.4m² floor space. Polypropylene construction aids with damping.

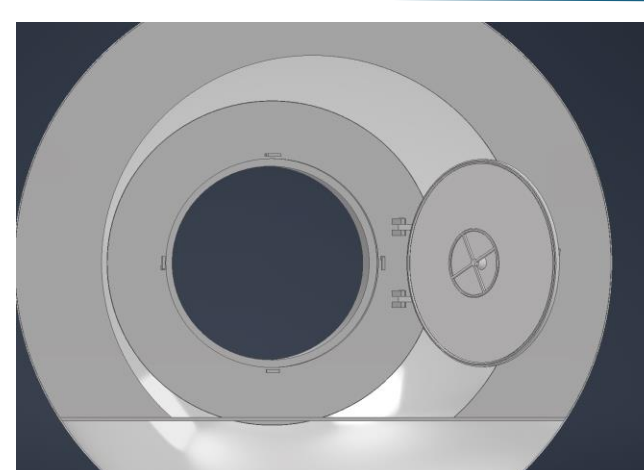

Door Hatch

An aluminum 2216 circular door allows for crew entry and exit. The door seals with multiple cammed wedging locks against a gasket.

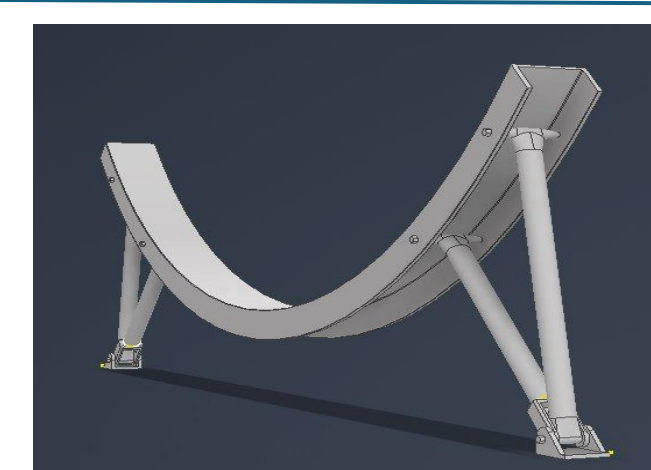

Leg-Saddles

Al 2216 saddles cradle the module. Hollow Ti 10-2-3 legs support the saddles and attach to foot pads which anchor to regolith.

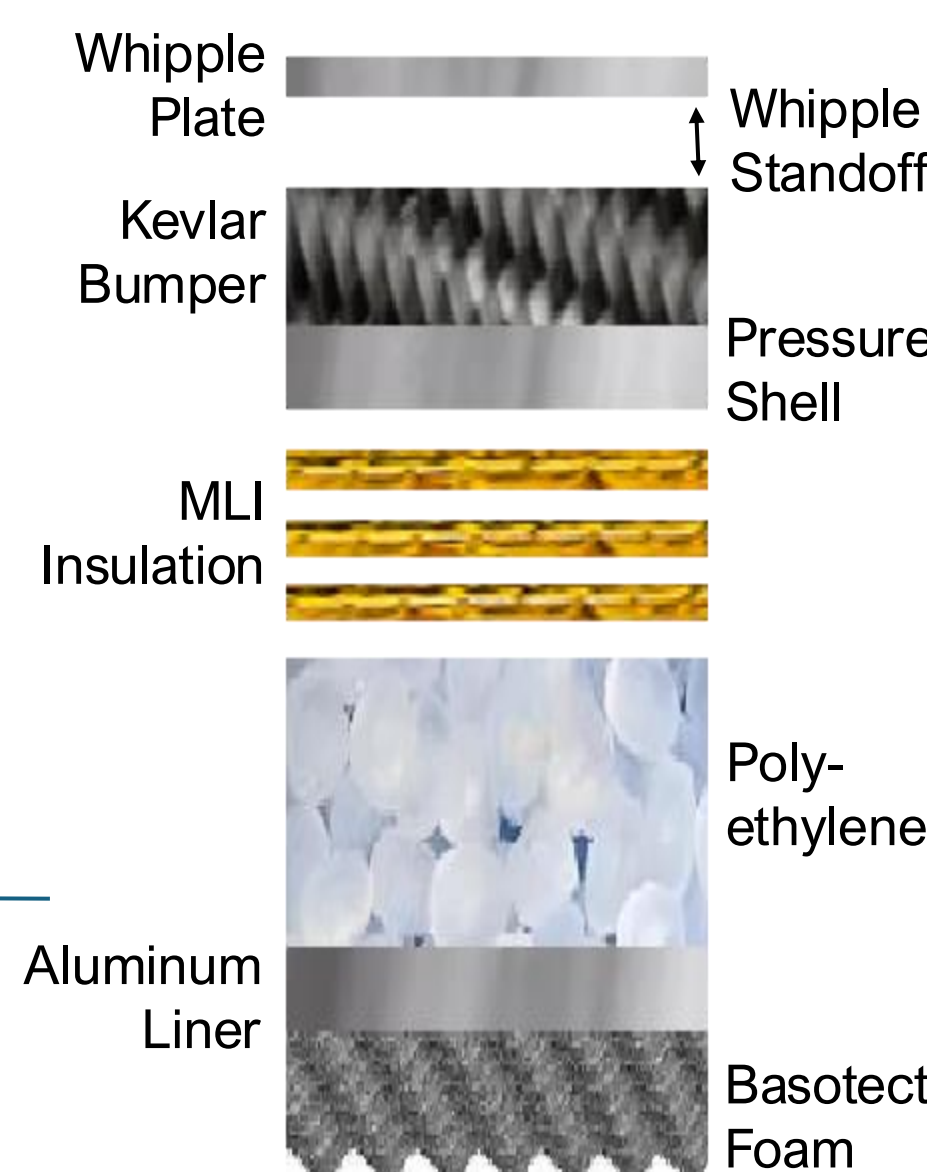

Wall Layer Cross-section

An external Whipple shield and Kevlar bumper resist micro-meteoroid impacts. Polyethylene and MLI blankets absorb radiation and provide thermal insulation. Basotect foam damps vibrations and reducing excess noise.

Simulated Testing

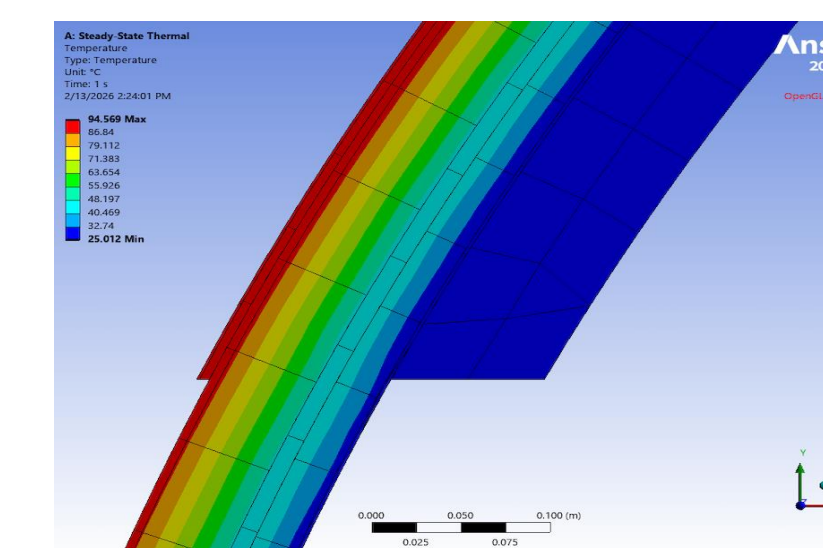

Steady State Thermal Hot
Heat transfer across the module's wall layers were simulated using ANSYS. The tests confirmed that the module is sufficiently insulated against hot Lunar conditions.

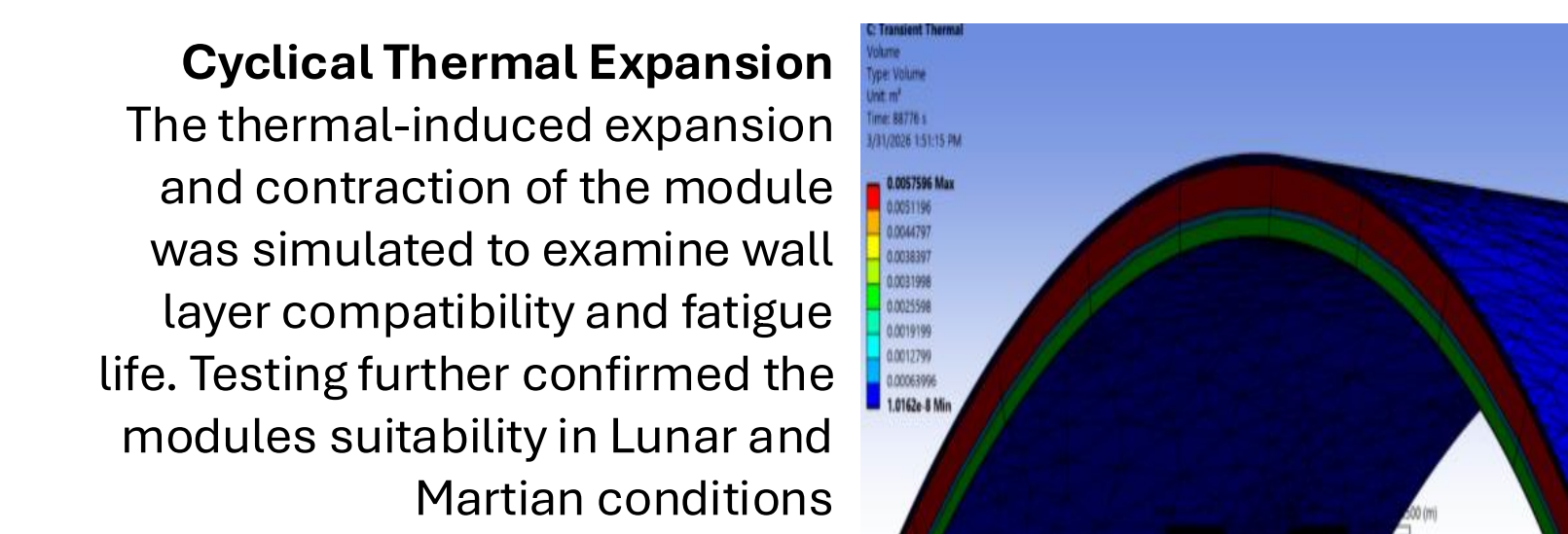

Cyclical Thermal Expansion
The thermal-induced expansion and contraction of the module was simulated to examine wall layer compatibility and fatigue life. Testing further confirmed the modules suitability in Lunar and Martian conditions

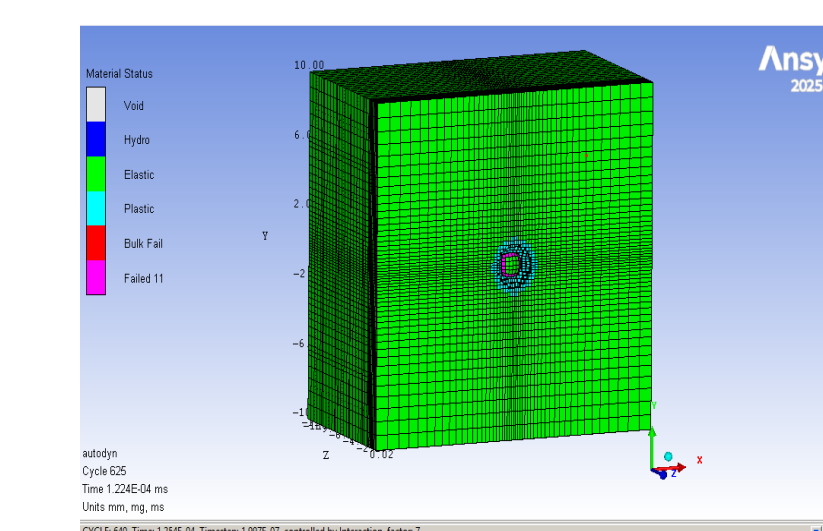

Micrometeoroid Impact
To test worst-case impact conditions, a 1mm diameter projectile hit at 20,000m/s directly against Kevlar shielding (no Whipple impact). The projectile was stopped with 10% penetration of the shield.

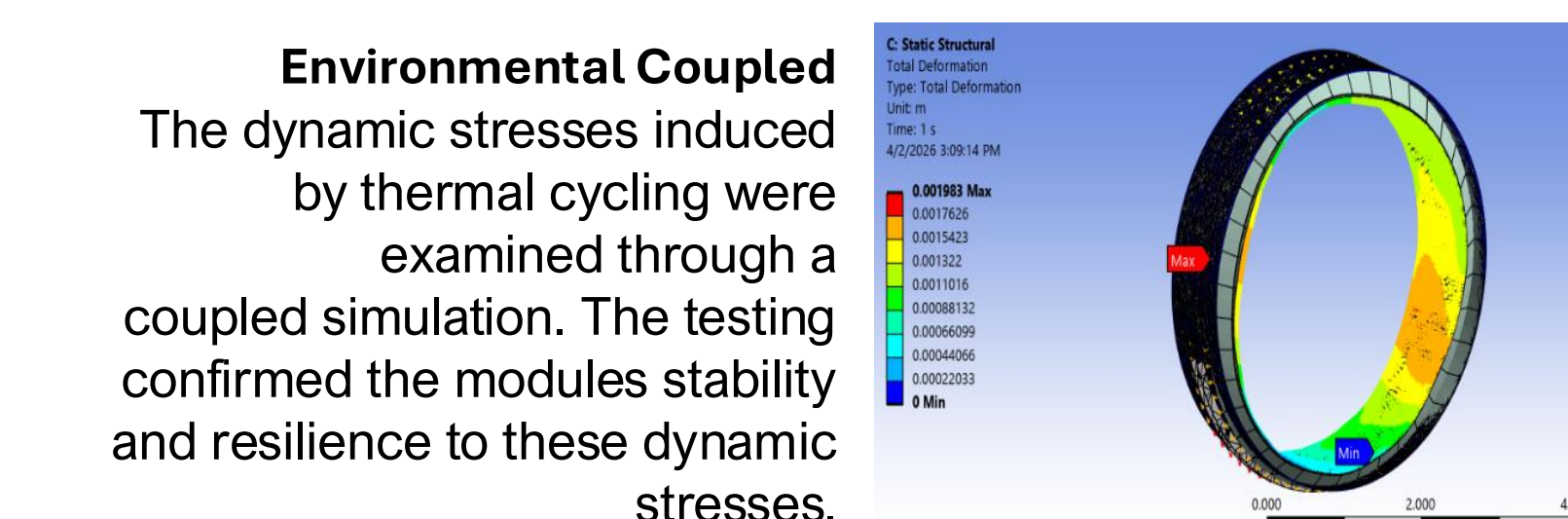

Environmental Coupled
The dynamic stresses induced by thermal cycling were examined through a coupled simulation. The testing confirmed the modules stability and resilience to these dynamic stresses.

Acknowledgments

- Mr. Robert Nuckols - NASA Mentor
- Dr. Tim Urban - NASA Texas Space Grant Consortium
- Dr. Mohammad Biswas - UT Tyler
- University of Texas at Tyler, ME Department

References

[1] NASA. Moon to Mars Architecture - White Papers. 13 Dec. 2024, <https://www.nasa.gov/moontomarsarchitecture-whitepapers>. Accessed 6 Oct. 2025.
 [2] NASA. Artemis. 25 Sept. 2023, <https://www.nasa.gov/feature/artemis>. Accessed 1 Oct. 2025.
 [3] SpaceX. Falcon Heavy. <https://www.spacex.com/vehicles/falcon-heavy/>. Accessed 24 Sep. 2025.
 [4] Procurement Divisions and Offices. National Aeronautics and Space Administration, <https://www.nasa.gov/reference/procurement-divisions-and-offices/>. Accessed 8 Oct. 2025.